

Spring Loaded Contacts
With PRECI-DIP Integrated CLIP

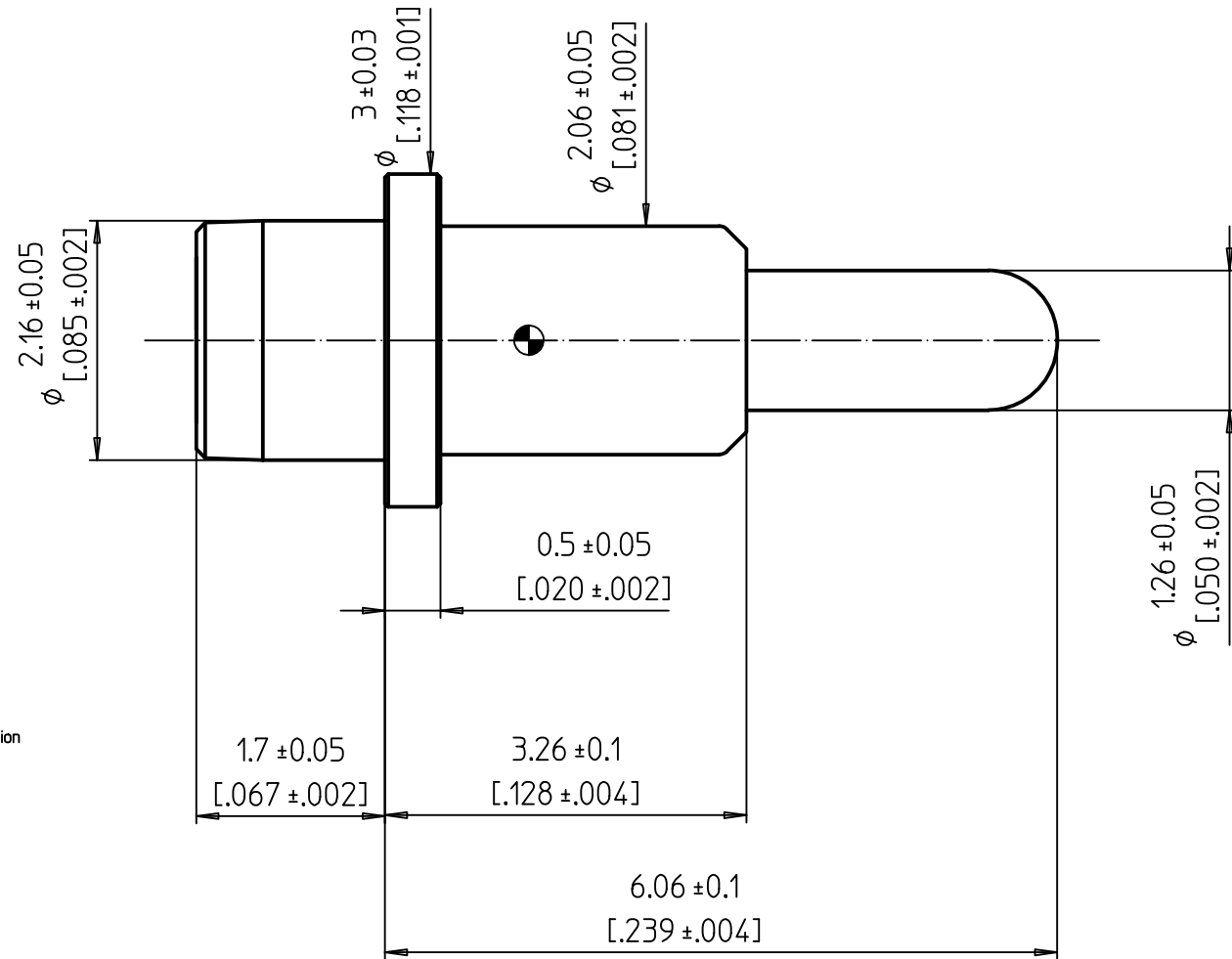
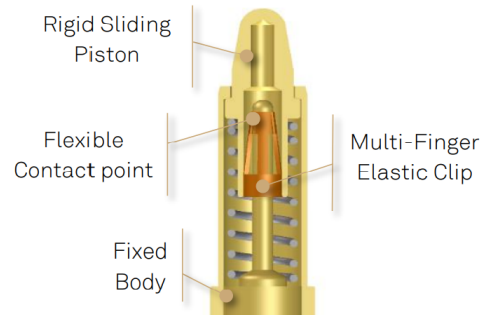

NOTES:

MECHANICAL REQUIREMENTS:

Durability: 20'000 cycles at Hnom
Theoretical stroke: S= 1.70 mm [0.067']
Spring forces (F):
Finit= 0.46 N
F1= 0.60 N at H1= 5.86 mm
Fnom= 1.11±0.32 N at Hnom= 5.11 mm
F2= 1.62 N at H2= 4.36 mm
Recommended working range: between H1 and H2
Forces are measured in mean value of compression / decompression

ELECTRICAL REQUIREMENTS:

Contact resistance:
R= 30 mOhms max in static mode at Hnom
Current per individual contact in free air at ambient temperature:
ICont= 5 A at Hnom with temperature raise max 30°C

ENVIRONMENTAL REQUIREMENTS:

Operating temperature: -25 °C / +125 °C
Storage temperature: -40 °C / +125 °C
Relative humidity: 5% / 95%

MATERIALS / PLATINGS:

Contact interfaces plated with 0.5 µm [20µ'] gold over Nickel
Spring: Stainless steel
Clip : Beryllium Copper

SOLDERING :

Recommended PCB pad size : 3.2 mm [0.126']
Recommended Moulding Hole 2.30 mm [0.09']
Solderability J-STD-002A. Test A 245°C, 5s, solder alloy SnAg3.8Cu0.7
Resistance to soldering heat J-STD-020C, 260°C, 20S
This recommendation may vary regarding your soldering process

High Reliability
Spring Loaded Contact



Remplace:

Remplacé par:

15:1

Dessiné

15.12.2022

C.Bidault

Contrôlé

N° dessin

Révision

90625-AS

P3

12

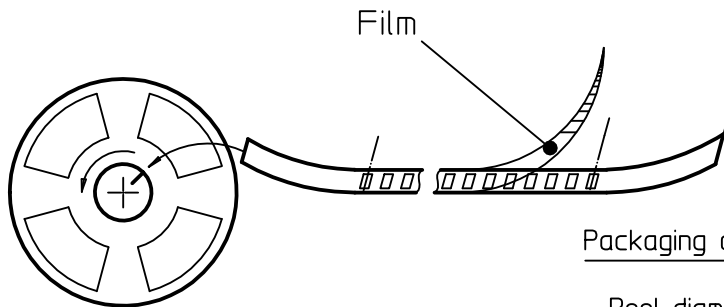
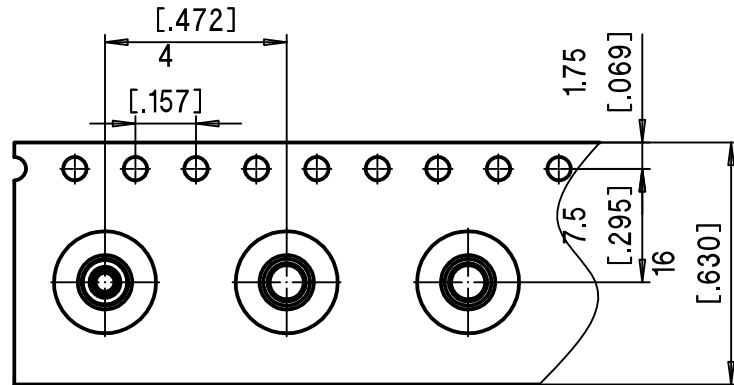

Packaging details :

- Reel diameter 380 mm
- Tape length 11.9 m
- Quantity per reel 900 pcs

NOTES:

MECHANICAL REQUIREMENTS:

Durability: 20'000 cycles at Hnom
Theoretical stroke: S= 1.70 mm
Spring forces (F):
Finit= 0.46 N *
F1= 0.60 N at H1= 7.56 mm *
Fnom= 1.11±0.32 N at Hnom= 6.81 mm
F2= 1.62 N at H2= 6.06 mm *
Recommended working range: between H1 and H2
Forces are measured in mean value of compression / decompression

* Theoretical values of spring design

ELECTRICAL REQUIREMENTS:

Contact resistance:
R= 50 mOhms max in static mode at Hnom
Current per individual contact in free air at ambient temperature:
ICont= 5 A at Hnom with temperature raise max 30°C

ENVIRONMENTAL REQUIREMENTS:

Operating temperature: -40 °C / +125 °C

MATERIALS / PLATINGS:

Barrel: CuZn36Pb3 - min 0.125 µm Au / 2.5 µm Ni
Piston: CuZn36Pb3 - 0.5 µm Au / 2.5 µm Ni
Clip: BeCu C17200 - 0.75 µm Au / 2.5 µm Ni
Rod: CuSn4Pb4Zn4 - 0.5µm Au / 2.5 µm Ni
Spring: Stainless steel

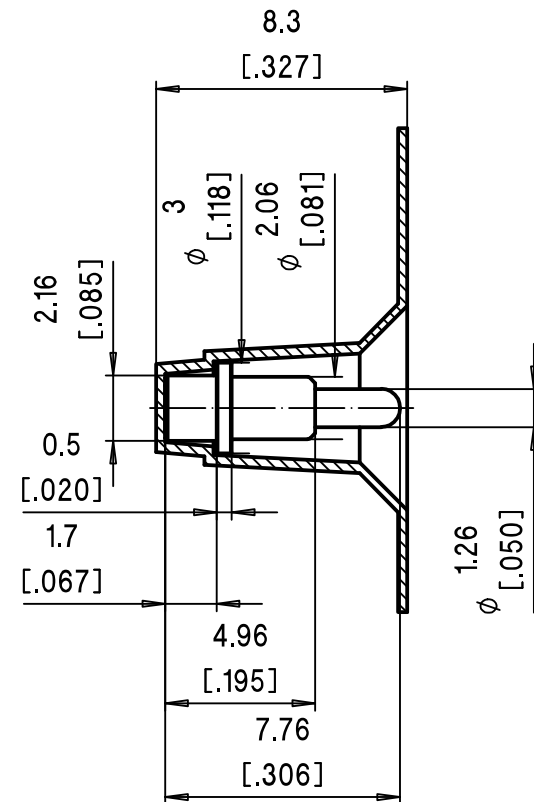

High Reliability
Spring Loaded Contact



Remplace:			
Remplacé par:			
2:1	Dessiné	24.11.2023	C.Bidault
	Contrôlé		
N° dessin			Révision
90625-AS-02			